

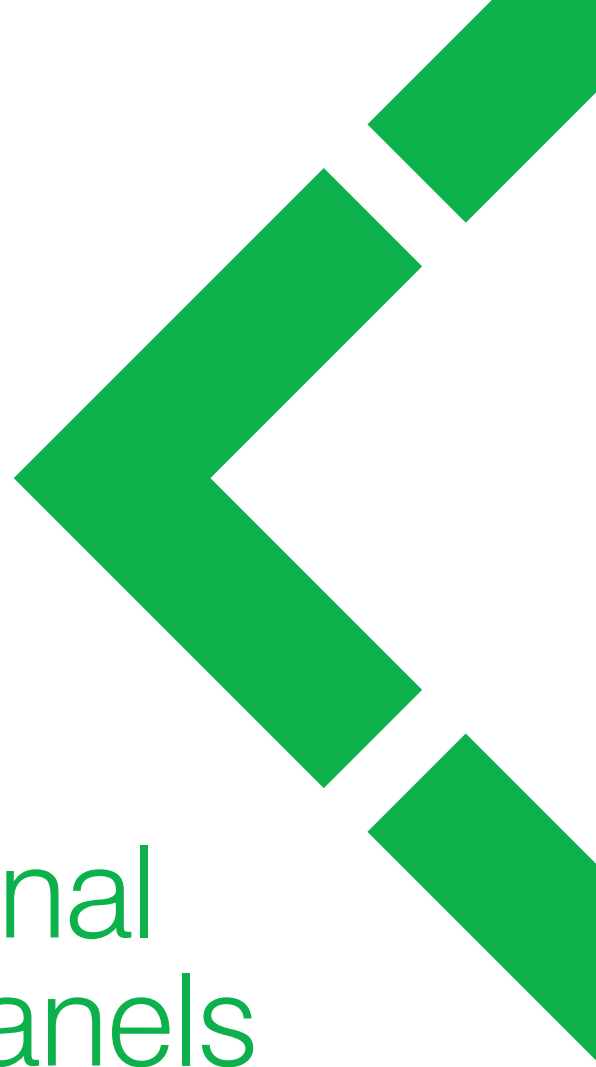

InfraBuild

Building futures through sustainable steel



FDN1 Support of External Concrete Wall Panels

2000

The information contained in this document is for general information purposes only. While we endeavour to keep the information up-to-date, InfraBuild does not guarantee, and accepts no legal liability, for the accuracy, reliability, currency or completeness of any material. InfraBuild recommends that users exercise their own skill and care with respect to their use of the content within. The content within is not a substitute for independent professional advice and users should obtain any appropriate professional advice relevant to their particular circumstances. Standards and Codes of Practice should be read in conjunction with relevant Guidance Notes.

STEEL PORTAL FRAME BUILDINGS

Support of External Concrete Wall Panels

by **I.D. Bennetts and K. W. Poh**
 Centre for Environmental Safety and Risk Engineering
 Victoria University of Technology

INTRODUCTION

External Wall Construction

Steel portal frames are commonly used for single-storey construction, particularly for factory and warehouse buildings. These frames provide support to a steel roof and a variety of forms of external wall construction including: steel sheeting supported by girts, masonry, dado walls, precast concrete panels and tilt-up concrete panels.



steel wall



dado wall

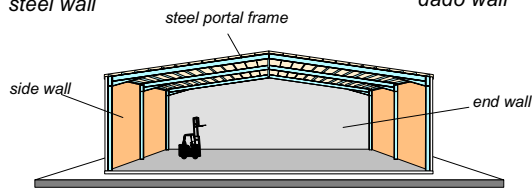

concrete panel wall



masonry wall

In the event of a major fire within such a building, it is possible that the external wall, or part of it, may collapse outwards. This possibility has been realised in a number of fires and safety concerns have been raised by Australian fire fighters with respect to the detachment of concrete panels in fire.



failure of connections causing external wall panels to collapse outwards during fire

This outwards collapse of external concrete wall panels is seen as an issue for fire fighters who may be positioned at various locations outside the building in close proximity to a wall. It is interesting to note the fire fighters do not see the same threat to be associated with the collapse of unreinforced masonry walls since such failure is considered as "progressive", giving adequate warning before final collapse.

BCA Requirement

The Building Code of Australia (BCA) [1] is concerned to prevent the outward collapse of external concrete wall panels. Thus *performance requirement* (CP5) states: "A concrete external wall that could collapse as a complete panel (eg. tilt-up and pre-cast concrete) must be designed so that in the event of fire within the building the likelihood of outward collapse is avoided". These requirements apply to buildings having a rise in storeys of not more than 2.

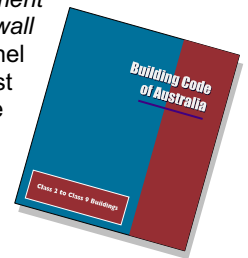

The BCA requirement applies to buildings having a rise in storeys of not more than 2. In Specification C1.11, the BCA gives *deemed-to-satisfy provisions* that are deemed as satisfying this *performance requirement*. The solutions given in this publication may be assumed to satisfy Specification C1.11 of the BCA.

In reality, the outwards collapse of wall panels is a function, to a lesser extent, of the behaviour of the wall panel and bare steel frame; and to a larger extent, of the connections between the frame and the panel. The purpose of this publication is to further discuss these issues and provide practical details that may be used directly by the engineer for the design of the connections. The same details have been presented in an earlier publication [2]. This publication is aimed at better illustrating the basis and details of the design solutions.

How do Steel Portal Frames Deform in Fire?

Advanced analysis [3] and observation of frames in fire have shown that when a steel portal frame experiences high temperatures during a severe fire, the fire-affected steel members will plastically deform and the frame take the shape shown below. The columns on one side of the frame will slope outwards whilst the columns on the other side will slope inwards.

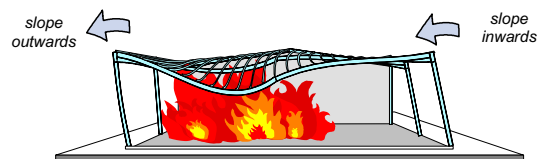

The extent to which the columns move out is mostly dependent on the extent of downwards deflection of the rafters. Even if the rafters touch the floor of the building, the column sloping outwards will be prevented from moving further by the rafter. Thus the frame itself will not deform as a four-pin mechanism leading to collapse of the frame outside the line of the building — thereby endangering persons outside or adjacent property.

DESIGN PRINCIPLES

How to Prevent Outward Collapse of External Concrete Wall Panels

There are two possible approaches to designing external wall panels against outwards collapse. The first approach is to ignore the presence of the steel frame and design the wall panels to resist fire exposure—assuming them to act independently of the frame. In this case the connections between the frame and the wall panels do not matter. However, the wall panels must be able to resist a worst-case fire with no support being provided at the top of the panels.

The second approach, which is the focus of this publication, is to design the connections between the panels and the frames such that they will not fail during the fire. This does not mean that all connections must be designed in this way but only those which offer necessary support.

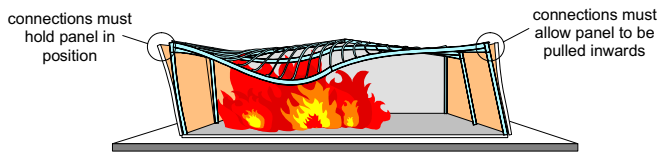

These connections must be designed such that, if the columns associated with the supporting frames deform outwards, they will be capable of holding the panels in inclined positions. Similarly, if the supporting columns slope inwards, the connections must be capable of pulling the panels inwards with the frame.

What Type of Connection is Suitable?

The development of a fire within the building will result in a significant thermal gradient across the thickness of a wall panel. This gives rise to differential thermal expansion and thermally induced curvature. As a result, the panel will tend to bow towards the fire, causing the corners to curve outwards.

If the movement of the panels is restricted, forces will develop at the points of restraint. Obviously, the magnitude of the forces will depend on the degree of restraint imposed on the panel, i.e. high restraint will lead to the development of high forces; conversely, low restraint will lead to development of low forces. In the latter case however, large movements of the panel must be accommodated.

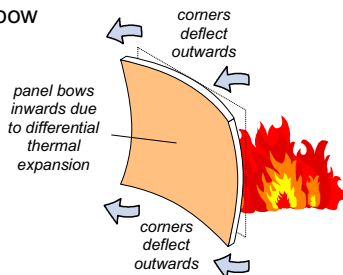

All connections between wall panels to their supporting structure necessarily impose a degree of restraint on the movement of the panels during fire. Hence, they must be designed to accommodate the appropriate levels of forces and deformations in order to prevent the failure of the connections.

Rigid connection

When the potential movement of a panel at the points of support is relatively small, a rigid type of connection may be used. Such situations arise when

- the panel is short
- the panel is supported at the top and bottom only
- the panel is supported by a weak column

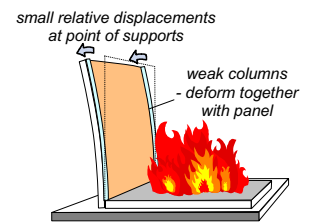
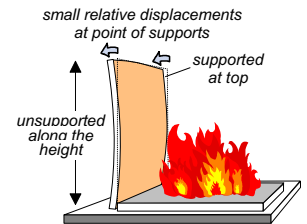
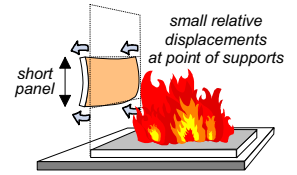

An example of a rigid connection is shown below. Such connections allow relatively small movement between the wall panels and the supporting steel member. Laboratory tests [4] have shown that these connections can deform in a relatively ductile manner under load.

Flexible connection

When a tall panel is supported by a relatively stiff structure, e.g. strong columns or by another panel at right angle to the plan of the panel, the potential separation of the panel and the support at the top, where the connections are usually located, will be large.

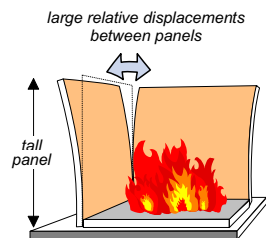
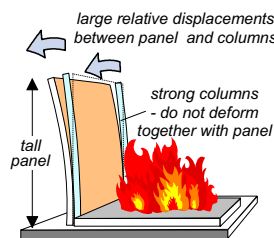

In such situations, it becomes unacceptable to use a rigid connection to support the panel at the top. A practical solution then is to use a flexible connection which can stretch during fire to minimise the development of high restraining forces. An example of such a flexible connection is shown below.

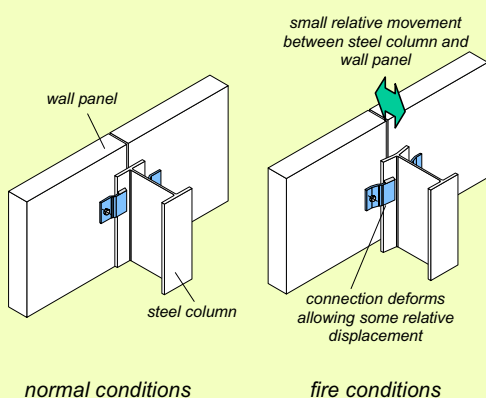

example of a rigid connection



a rigid connection tested under laboratory conditions

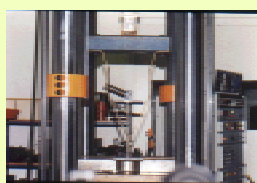

a flexible connection tested under laboratory conditions

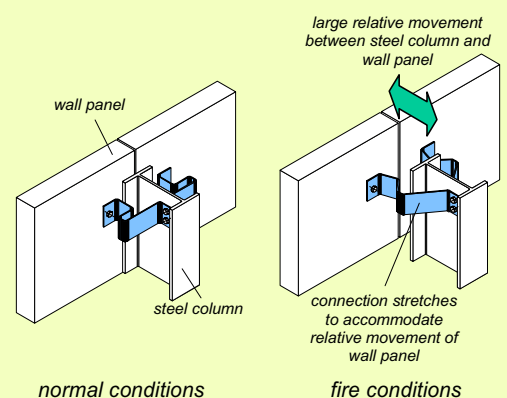

example of a flexible connection

DESIGN DETAILS

Introduction

The following sections give details of solutions which may be taken as satisfying BCA clause C1.11. The details have been derived based on assumptions that are consistent with those implied by the design conditions stated in Specification C1.11.

Connections are described as *rigid* or *flexible*; wall panels as being *short* or *tall*; and supporting columns as *weak* or *strong*. A wall panel is considered *tall* if its height is greater than 2.5 m. A supporting column is considered *strong* if its ambient bending capacity is greater than 50 kN-m.

Rigid Connections

Short panels

When short external wall panels (height ≤ 2.5 m) are used, each panel will be connected to the supporting members at the four corners using rigid connections with details as shown below. The details are suitable for column spacings up to 10 m, for side or end wall situations.

It is to be noted that the connection plates must be welded to the flange of the supporting columns. This is to prevent the panels from disengaging from the supporting columns during fire.

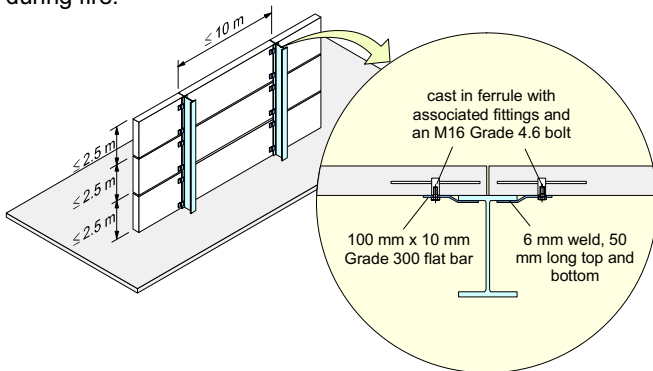

Tall panels supported at top and bottom only

This is typical of an end wall situation where the panels are supported at the top by the roof structure only. In this situation, the panels may be rigidly connected to a raker member which, in turn, is connected to the purlins. Details are shown below.

Each panel must have at least two connections to the raker member unless the panels are designed to act as a single unit (eg. interlocking panels).

The spacing of connections along the raker member should not exceed 2 m.

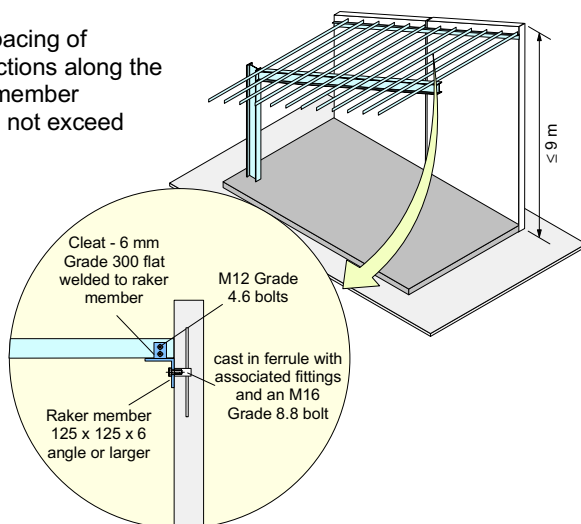

Tall panels supported by weak columns

This is also typical of an end wall situation where the panels are supported by lightweight columns or mullions (having a bending capacity of less than 50 kN-m). In this situation, the panels may be rigidly connected to the columns or mullions which, in turn, are supported by the roof members. Details of the connections are shown below.

In this situation, the designer must also ensure that the attached roof members will enable the connections to achieve their capacity.

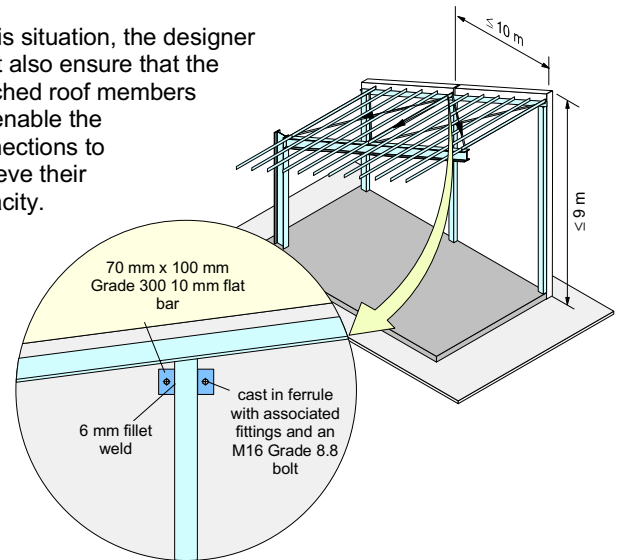

Flexible Connections

Tall panels supported by strong columns

When an external wall consists of tall panels supported by columns having a bending capacity of more than 50 kN-m, the panels should be connected to the columns at the top by flexible connections. It is anticipated that, during fire, all other connections will fail and the panels will be supported by these flexible connections only.

Two sets of details for the flexible connections are given below: one for larger columns and panels; and the other for smaller columns and panels. These may be used for either side or end wall situations. Each of these connections has been detailed to allow substantial (as per BCA Specification C1.11) relative movement between column and panel.

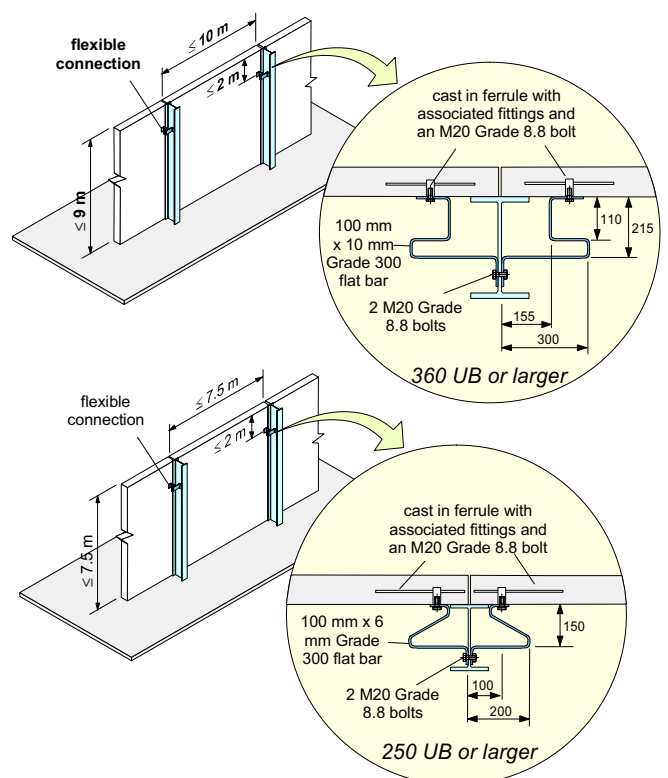

The same details apply for situations where the panels are supported at the corners or at the mid-width positions, as shown below, provided the panel heights and column spacings are within the appropriate limits given previously.

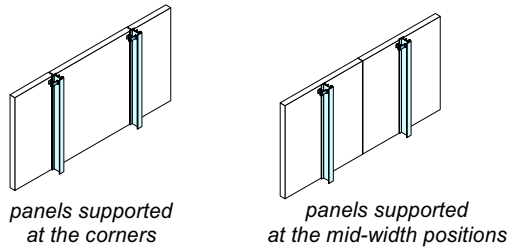

These details are also suitable for use with smaller panels, as shown below, provided the panels are designed to act as single units. Again, the appropriate limits for panel heights and column spacings as given previously apply.

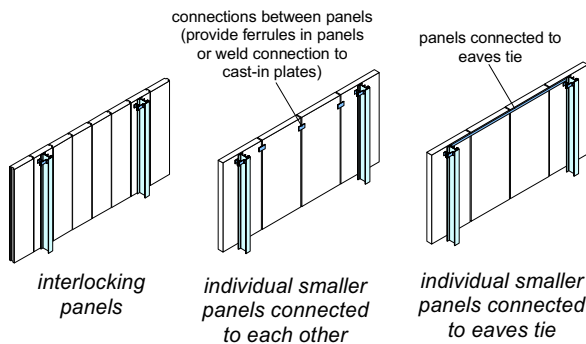

Tall panel supported by another tall panel

In situations where there is no column located at the corner of the building to support the panels, the panels at that junction may need to support each other. In these situations, adequate connection between the panels can be achieved by a single flexible connection. The details are similar to those where the panels are supported by strong columns. The figure below shows the details which correspond to the larger connection as detailed in the previous section. For smaller panels, the smaller connection given in the previous section may be used, provided the panels sizes are within the limits as indicated previously.

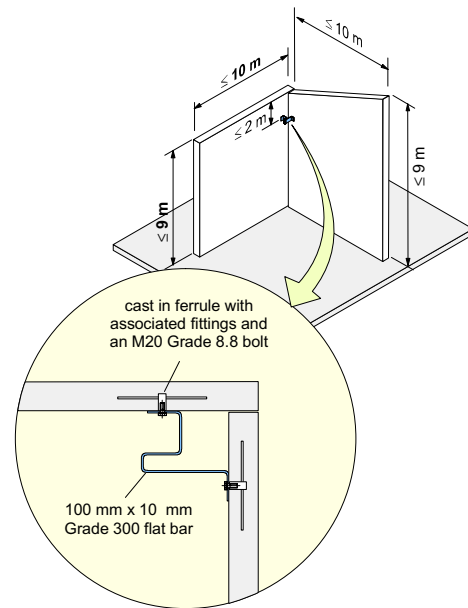

REFERENCES

- [1] "Building Code of Australia 1996", Volume 1—Class 2 to 9, Australian Building Codes Board, 1996.
- [2] Bennetts, I.D. and O'Meagher, A.J., "Support of External Walls in Fire", BHP Structural Steel Development Group, Technical Note No. 1, March 1995.
- [3] O'Meagher, A.J., Bennetts, I.D, Dayawansa, P.H and Thomas, I.R., "Design of Single Storey Industrial Buildings for Fire Resistance", Journal of the Australian Institute of Steel Construction, Vol. 26, No. 2, May 1992.
- [4] Bortoli, A., "Aspects of the Behaviour of Single Storey Industrial Buildings in Fire", Master Degree Thesis, Victoria University of Technology, May 1995.



Further information can be obtained from OneSteel on:

Freecall **1800-1-STEEL**
1800-1-78335

OneSteel Website <http://www.onesteel.com.au>

Steel Portal Frame Buildings — Support of External Concrete Wall Panels

Written by: I.D. Bennetts and K.W. Poh
 Published by: OneSteel Manufacturing Pty Limited
 ABN 42 004 651 325
 Designed and illustrated by: K.W.Poh

August 2000